

# MANUAL DE MONTAJE

## F3



### MAMPARA FRONTAL DE DUCHA

1 HOJA CORREDERA + 2 FIJAS

F3

**1**

PRESENTAMOS PERFILES "U" DE FIJOS, EN PAREDES, NIVELANDOLOS A 3 MM. DEL BORDE DEL PLATO DE DUCHA Y MARCAMOS TALADROS.

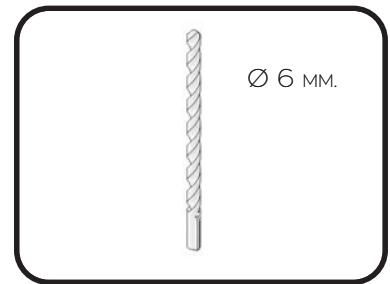
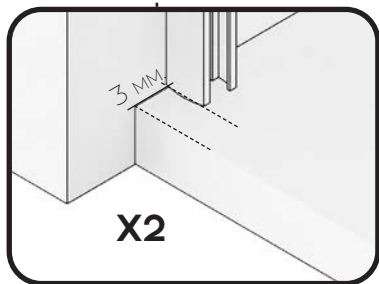
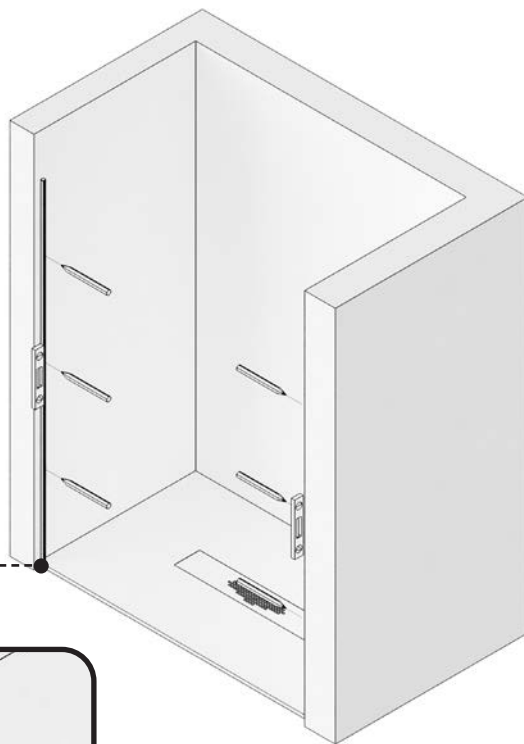

**2**

TALADRAR LAS PAREDES CON BROCA DE 6MM.



**3**

ATORNILLAR LOS PERFILES "U" A PAREDES, FIJANDOLOS CON TACOS DEL N° 6 Y LOS 6 TORNILLOS 4.2X32

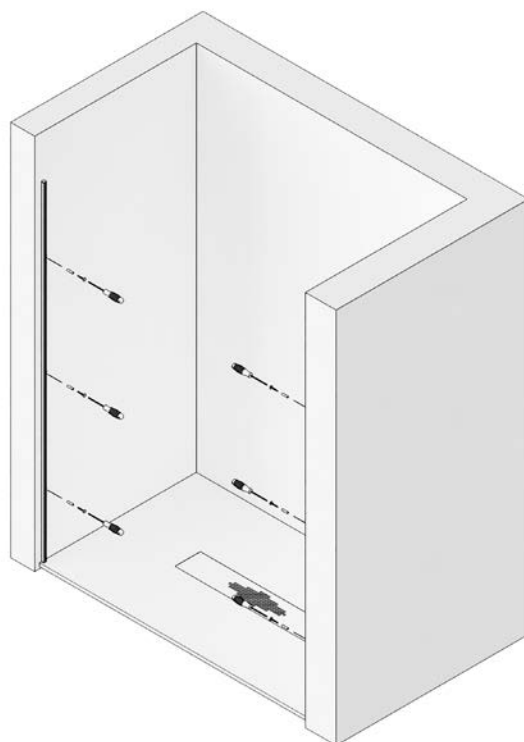

# 4

COLOCAMOS LAS GOMAS DE ESTANQUEIDAD INFERIORES EN LAS HOJAS FIJAS E INTRODUCIMOS LOS VIDRIOS EN LAS "U", SEGÚN CORRESPONDA SU POSICIÓN, APOYÁNDOLOS SOBRE ESTAS.

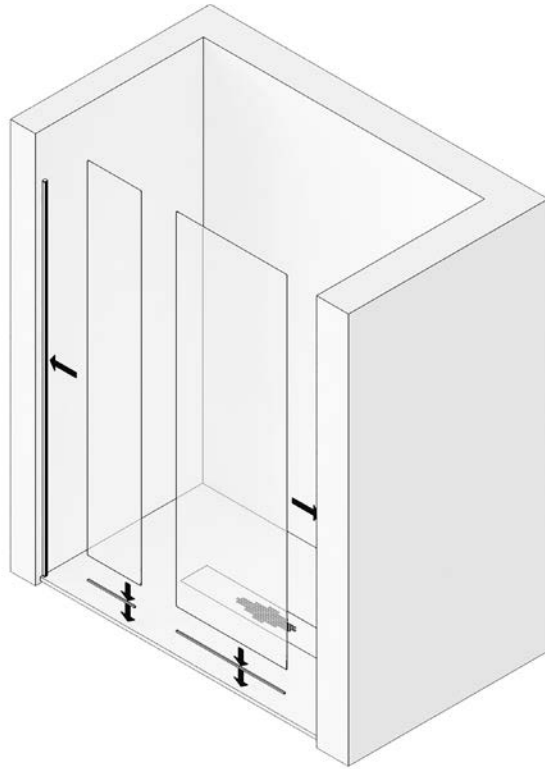

# 5

COLOCAR LA PINZA GUIA INFERIOR EN EL EXTREMO DEL VIDRIO FIJO CONTRARIO AL CIERRE, MONTANDOLA PREVIAMENTE SEGÚN CORRESPONDA SU POSICIÓN.

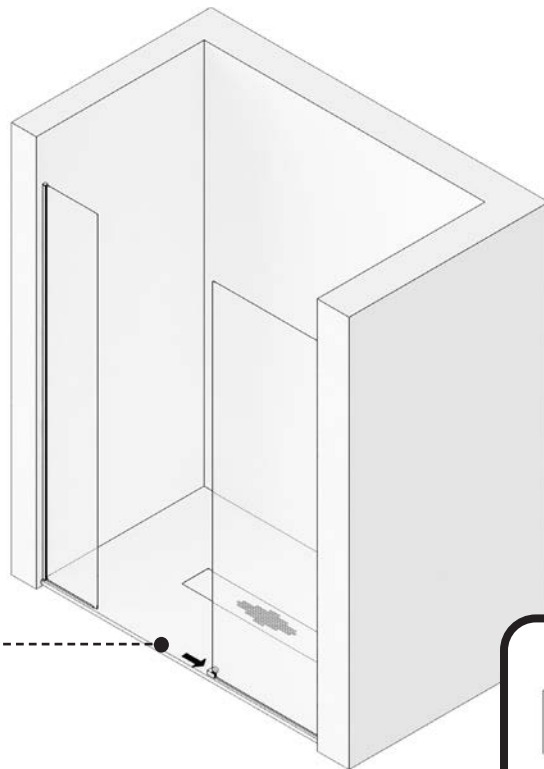

## MONTAJE PINZA GUIA INFERIOR

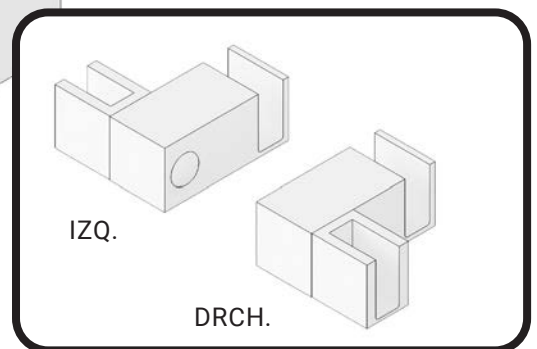
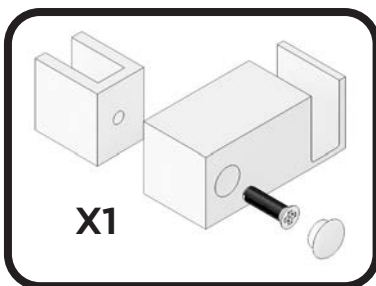

F3

**6**

PRESENTAR GUÍA SUPERIOR CON VASOS SOBRE LOS VIDRIOS FIJOS, NIVELAR Y MARCAR LOS TALADROS.

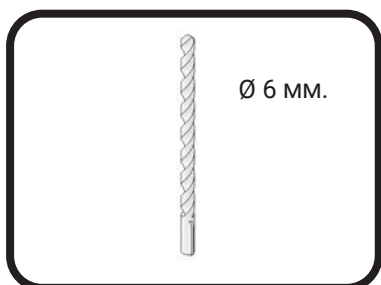
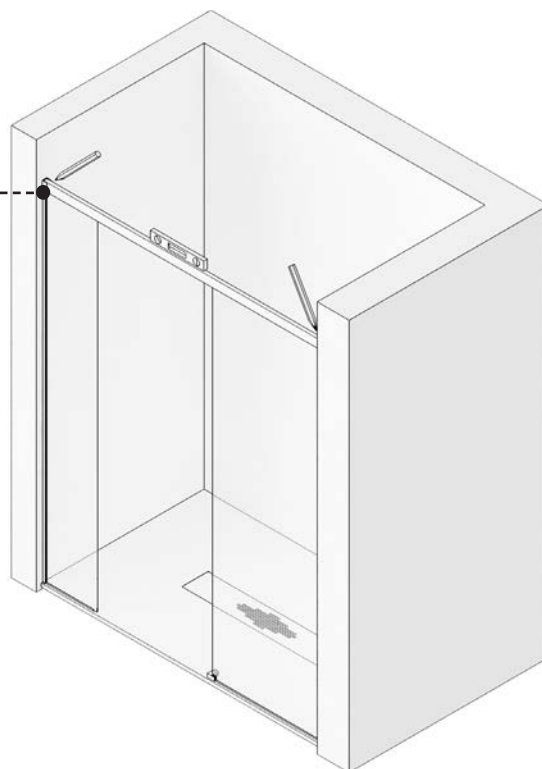
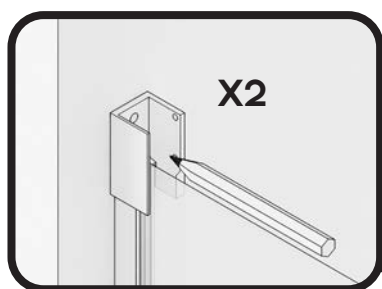

**7**

TALADRAR LA PARED CON BROCA DE 6MM.

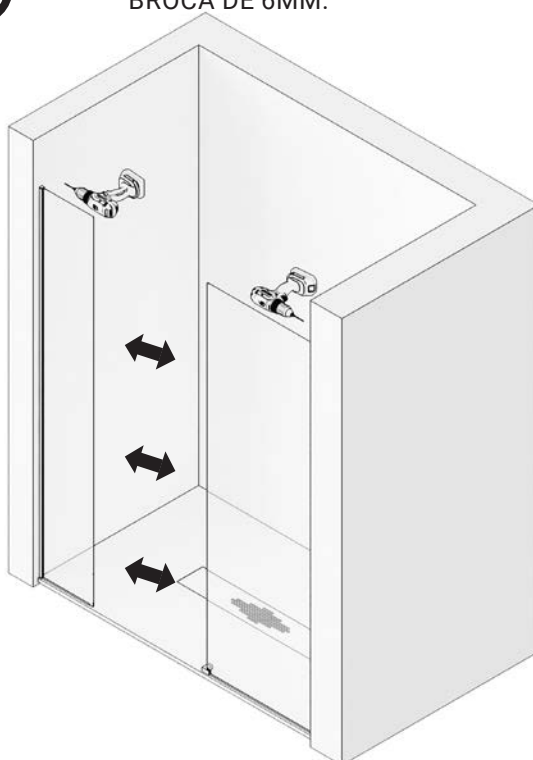

RETIRAR CRISTAL FIJO SI FUESE NECESARIO.

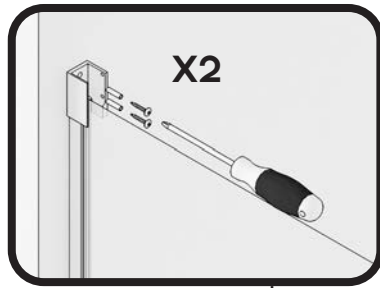

**8**

ATORNILLAR LOS VASOS SOPORTE GUÍA SUPERIOR A PARED.



**9**

INTRODUCIR LOS 2 TOPES FRENO EN GUIA SUPERIOR, DESPLAZANDOSLOS, UNO HACIA EL FINAL DE LA HOJA FIJA Y OTRO POR DELANTE DEL CIERRE DE HOJA. COLOCAR LA GUIA SUPERIOR EN LOS VASOS COGIDA A PARED Y FIJAR LA COGIDA A LA GUIA MEDIANTE LOS TORNILLOS PRISIONEROS CON LLAVE HALLEN. ENGOMAR CRISTALES FIJOS A PERFILES PAREDES Y A GUÍA SUPERIOR.

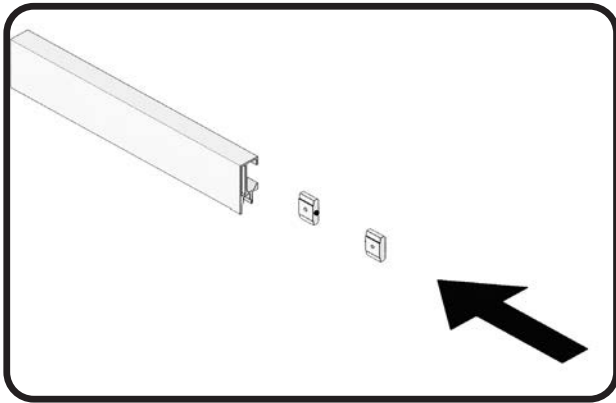

**10**

MONTAR CONJUNTO RUEDAS, GRADUADAS EN SU ALTURA MÁXIMA Y GOMA INFERIOR VIERTEGUAS EN LAS HOJAS CORREDERAS.

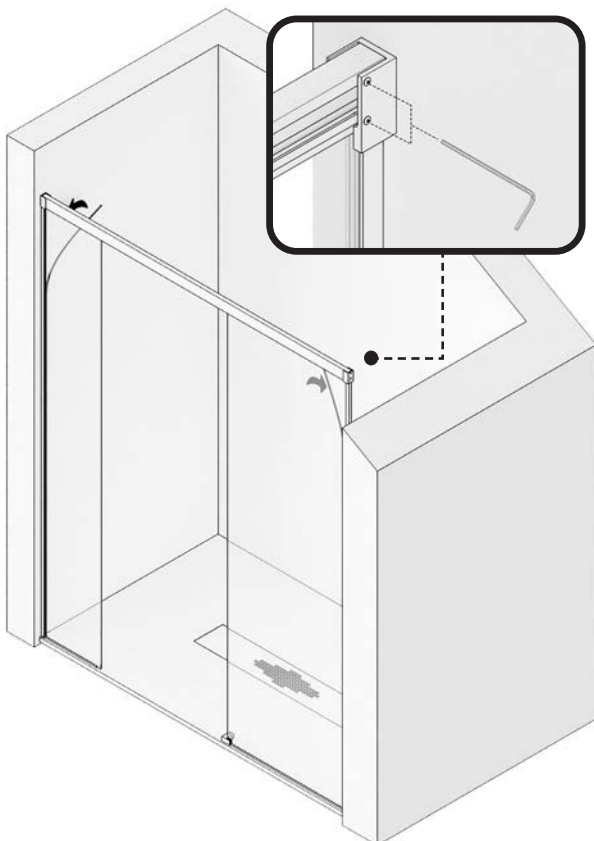

**ALTURA MÁXIMA**

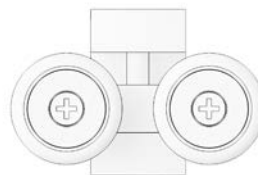

**ALTURA MÍNIMA**

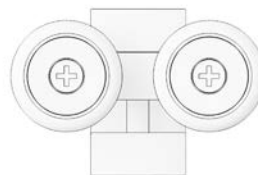

**X2**

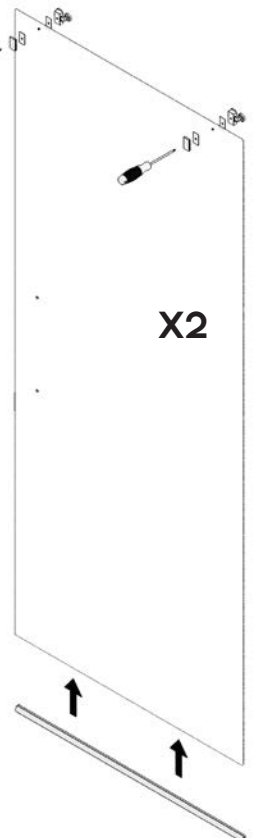

# 11

COLOCAR PERFIL CIERRE IMAN EN CANTO VIDRIO HOJA FIJA, SEGÚN CORRESPONDA, CON EL ALA IMAN HACIA EL INTERIOR DUCHA.



# 12

COLGAR LA HOJA CORREDERA EN LA GUIA SUPERIOR, INTRODUCIENDO EL CONJUNTO RUEDAS EN LA MISMA Y EN LA PINZA GUIA INFERIOR, GRADUANDO EN ALTURA Y NIVELANDO LA HOJA CORREDERA, HACIENDO DESCENDER LA HOJA MEDIANTE LOS TORNILLOS DE REGULACION DE RUEDAS, CON UN DESTORNILLADOR.

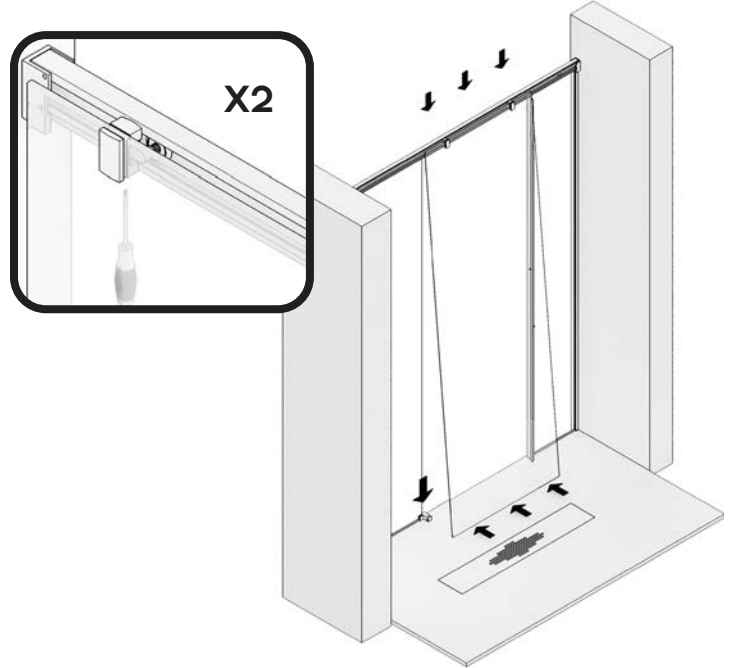

# 13

COLOCAMOS LAS GOMAS ALA DE CRUCE, UNA EN EL FIJO Y OTRA EN LA HOJA CORREDERA. COLOCAR EL ASA TIRADOR.

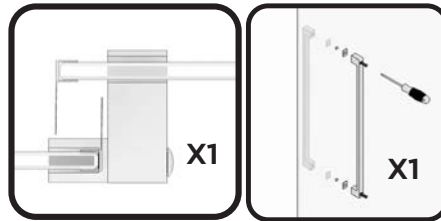

# 14

COLOCAR EL CIERRE GOMA IMAN FRONTAL EN EL CANTO EXTERIOR DE LA HOJA CORREDERA. APROXIMAR LA HOJA CORREDERA AL CIERRE IMAN, NIVELANDOLO.

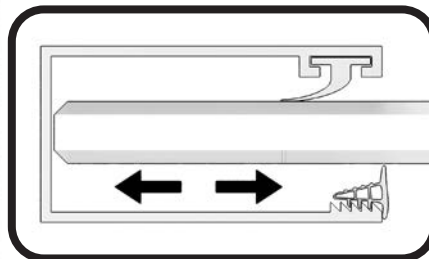

AJUSTAR EL JUEGO DE LOS VIDRIOS FIJOS SEGÚN NECESIDAD. FIJAR EL VIDRIO, ENGOMANDO EL CRISTAL CON EL PERFIL A PARED Y CON LA GUIA SUPERIOR.

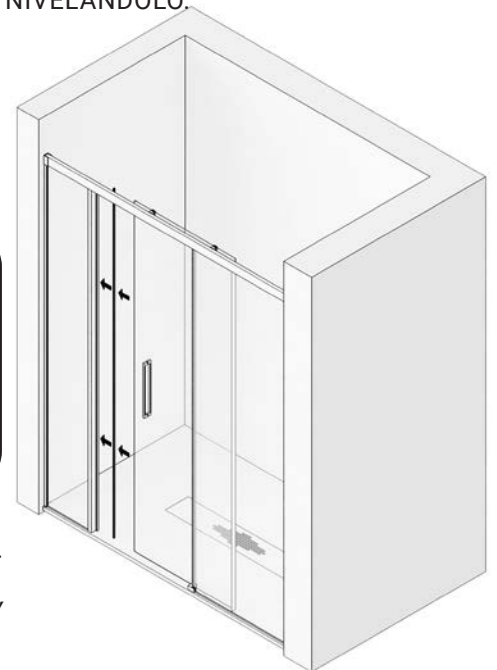

# 15

FIJAR LOS TOPES FRENO EN SU POSICIÓN, MEDIANTE SU TORNILLO PRISIONERO.

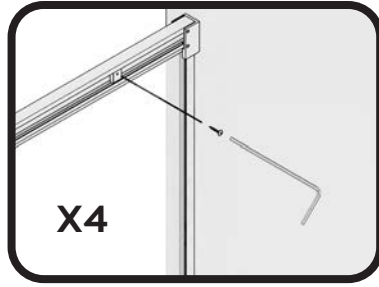

# 16

MEDIMOS, CORTAMOS, MONTAMOS SUS TAPONES Y PEGAMOS EL PERFIL DE ESTANQUEIDAD, DE PINZA INFERIOR A FINAL PUERTA, POR DELANTE DE LA HOJA CORREDERA.

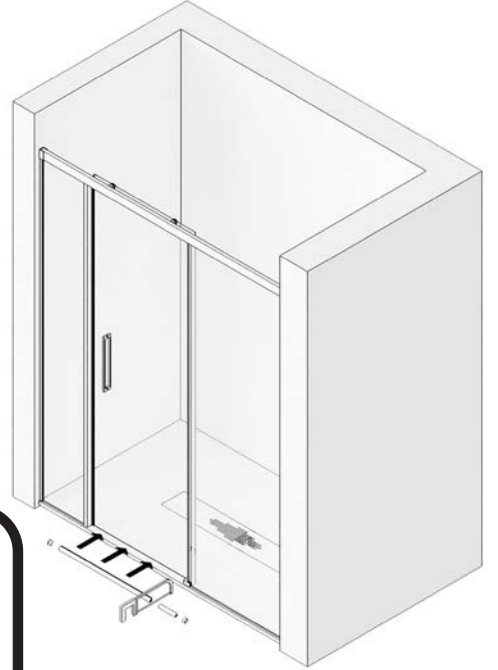

PERFIL DE ESTANQUEIDAD

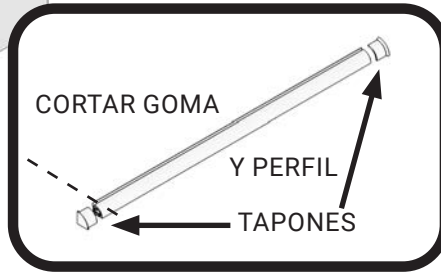





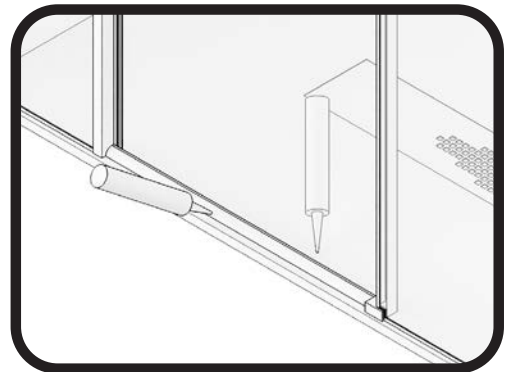



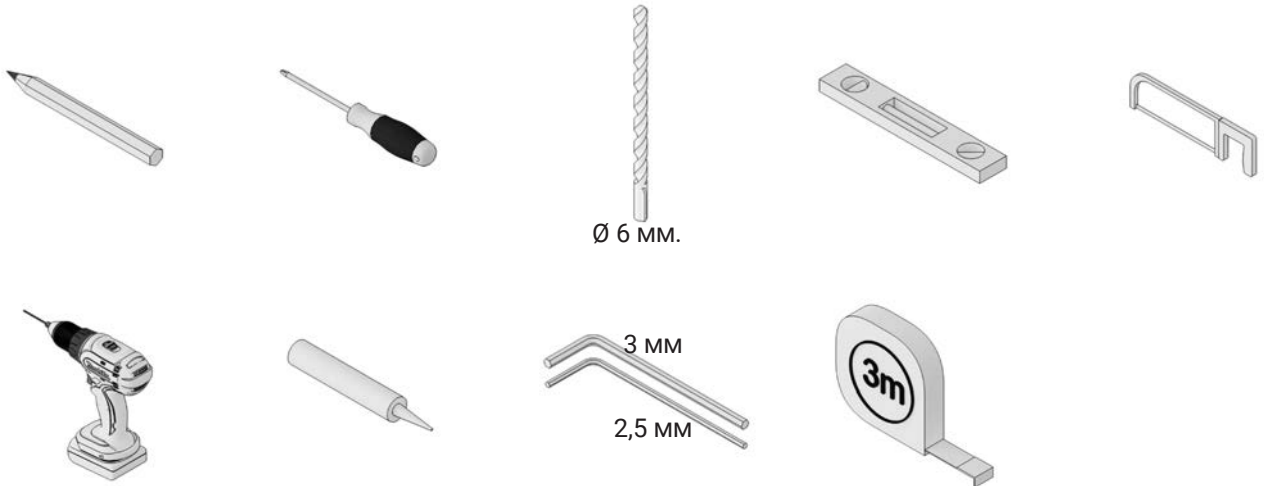

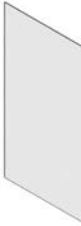
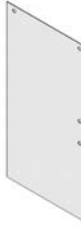

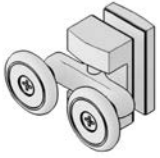
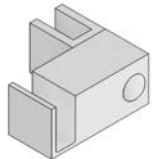



# 17

SELLAR CON SILICONA EL CONTORNO EXTERIOR DE LA MAMPARA.

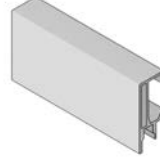

# F3



- |   |   |  |   |  |
|---|---|--|---|--|
| <p><b>2X</b></p>  <p>HOJA FIJA</p>                             | <p><b>1X</b></p>  <p>HOJA CORREDERA</p>                          | <p><b>2X</b></p>  <p>VASO O SOPORTE GUÍA</p>            | <p><b>2X</b></p>  <p>TAPA EMBELLECEDORA VASO<br/>SOPORTE GUÍA</p> | <p><b>2X</b></p>  <p>RODAMIENTO SUP DOBLE<br/>TÁMRFN</p>        |
| <p><b>1X</b></p>  <p>GUÍA PINZA INFERIOR</p>                 | <p><b>2X</b></p>  <p>TOPE FRENO</p>                            | <p><b>1X</b></p>  <p>ASA TIRADOR</p>                  | <p><b>10X</b></p>  <p>TACOS Nº 6</p>                           | <p><b>10X</b></p>  <p>TORNILLO 4,2 X 32</p>                   |
| <p><b>2X</b></p>  <p>TERMINAL PERFIL DE<br/>ESTANQUEIDAD</p> | <p><b>2X</b></p>  <p>PERFIL "U" FIJO A PARED</p>               | <p><b>2X</b></p>  <p>GOMA CUÑA FIJACION VIDRIO</p>    | <p><b>1X</b></p>  <p>PERFIL GUÍA SUPERIOR</p>                   | <p><b>1X</b></p>  <p>PERFIL DE ESTANQUEIDAD</p>               |
| <p><b>1X</b></p>  <p>PERFIL CIERRE IMAN<br/>CENTRAL</p>      | <p><b>2X</b></p>  <p>GOMAS DE ALA CRUCE<br/>FIJO/CORREDERA</p> | <p><b>1X</b></p>  <p>GOMA CIERRE IMAN<br/>FRONTAL</p> | <p><b>1X</b></p>  <p>GOMA ESTANQUEIDAD<br/>INFERIOR FIJO</p>   | <p><b>1X</b></p>  <p>GOMA INFERIOR<br/>VIERTEAGUAS PUERTA</p> |