

MANUAL DE MONTAJE

AFPF3



MAMPARA ANGULAR DE DUCHA

1 HOJA ABATIBLE + 2 FIJAS

AFPF3

1

PRESENTAR LOS PERFILES EXPANSORES DE LA HOJA FIJO SOPORTE PUERTA Y LATERAL FIJO, EN PAREDES, SEGÚN CORESPONDA SU POSICION, NIVELANDOLO, A 1 CM. DEL BORDE DEL PLATO DE DUCHA Y MARCAMOS TALADROS.

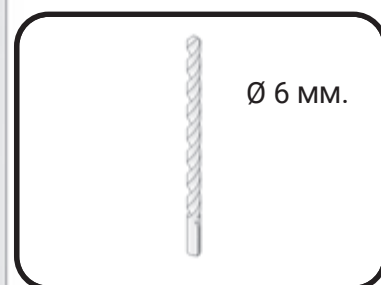
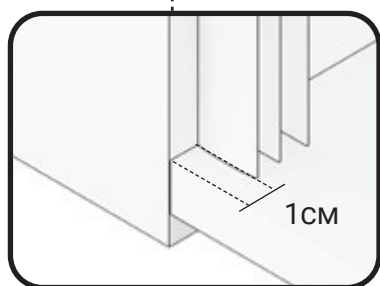

2

TALADRAR LA PARED CON BROCA Ø 6 MM.



3

ATORNILLAR LOS PERFILES EXPANSORES DE LOS FIJOS, FIJANDOLOS CON TACOS DEL N° 6 Y LOS 6 TORNILLOS 4.2X32.



4

COLOCAMOS LAS GOMAS DE ESTANQUEIDAD INFERIOR EN LA HOJA FIJA SOPORTE PUERTA Y EN EL LATERAL FIJO.



5

INTRODUCIMOS LA HOJA FIJA SOPORTE PUERTA PRE-MONTADA, EN SU MARCO EXPANSOR.



AFPF3



6

MONTAMOS ASA TIRADOR, GOMA INFERIOR BARREDERA Y GOMA CIERRE IMÁN ANGULAR, EN LA HOJA ABATIBLE.

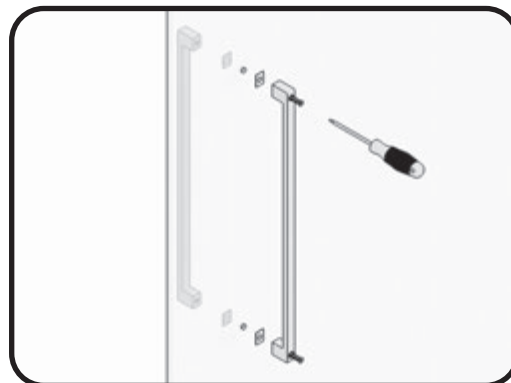

7

UNIMOS LA HOJA ABATIBLE A LA HOJA FIJA PRE-MONTADA, DESMONTANDO LA BISAGRA SUPERIOR PARA SU ANCLAJE, FIJANDOLA DESPUÉS.

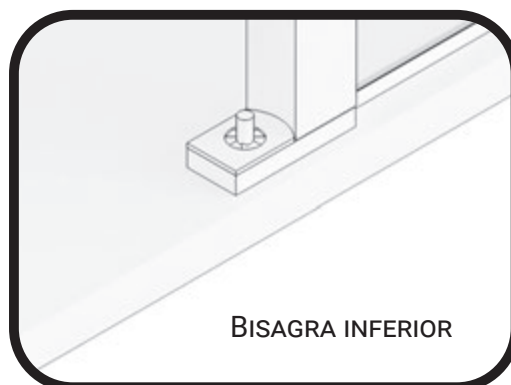

8

COLOCAMOS GOMA DE ESTANQUEIDAD INFERIOR Y GOMA CIERRE IMAN ANGULAR EN EL LATERAL FIJO.



9

INTRODUCIMOS EL LATERAL FIJO PRE-MONTADO EN SU MARCO EXPANSOR.



10

APROXIMAMOS Y NIVELAMOS LA HOJA ABATIBLE JUNTO CON SU HOJA FIJA, RESPECTO AL CIERRE AL VÉRTICE, SOBRE EL LATERAL FIJO. FIJAMOS LA HOJA FIJA SOPORTE PUERTA Y EL LATERAL FIJO A SU CORRESPONDIENTE PERFIL EXPANSOR CON LOS 6 TORNILLOS AUTORROSCANTES Y SUS RESPECTIVOS TAPONES, POR EL INTERIOR DE LA DUCHA.

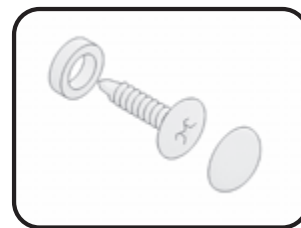
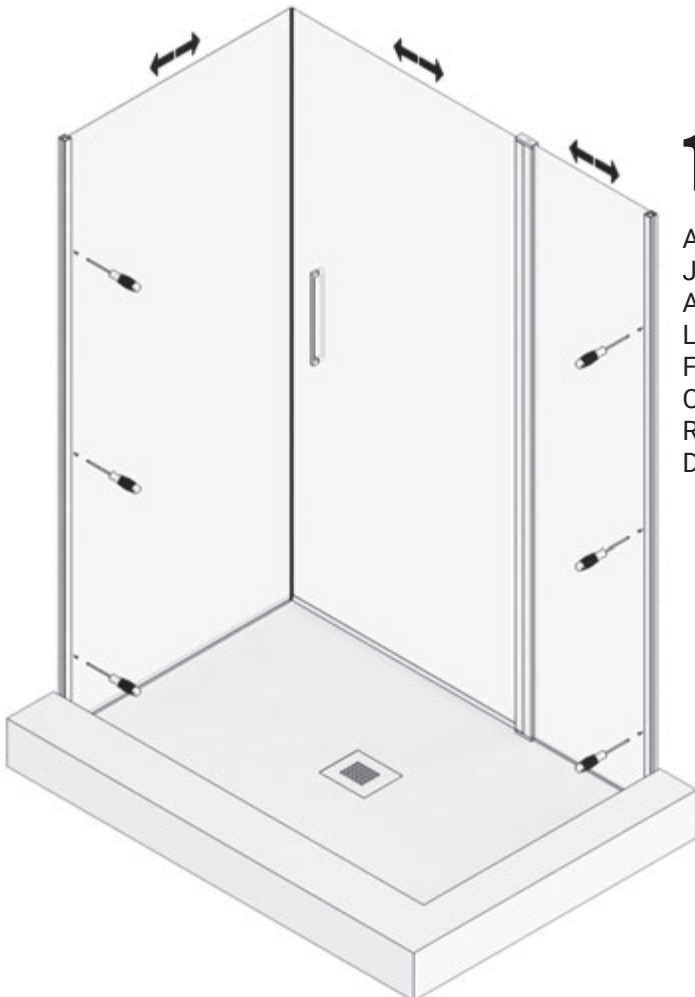

AFPF3

11

PRESENTAMOS, NIVELAMOS Y MARCAMOS LOS BRAZOS DE SUJECCIÓN SUPERIOR DE LAS HOJAS FIJAS, AJUSTANDO LA DISTANCIA AL CORTE DE LOS TUBOS DEL MISMO Y FIJAMOS A PARED Y VIDRIO.

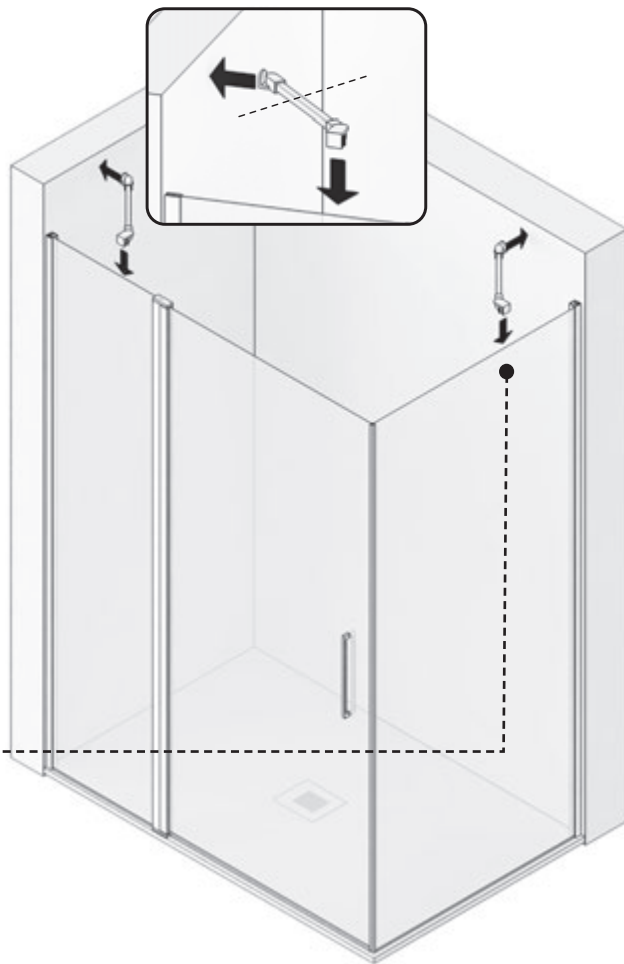
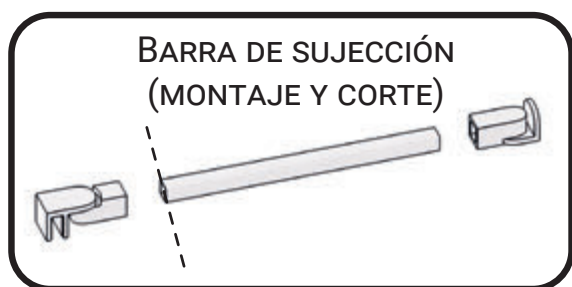

12

MEDIMOS, CORTAMOS Y PEGAMOS EL PERFIL DE ESTANQUEIDAD POR DELANTE DE LA HOJA ABATIBLE.

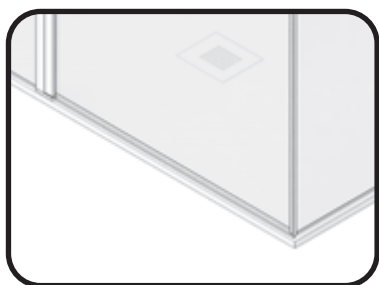

13

COLOCAMOS LAS 2 TAPAS
EMBELLECEDORAS SUPERIORES EN LOS
PERFILES EXPANSORES.

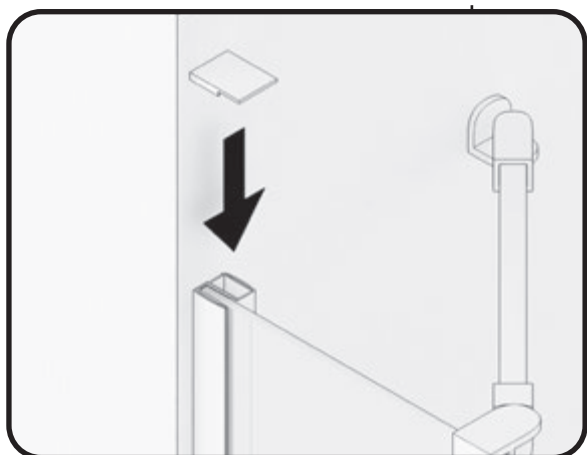





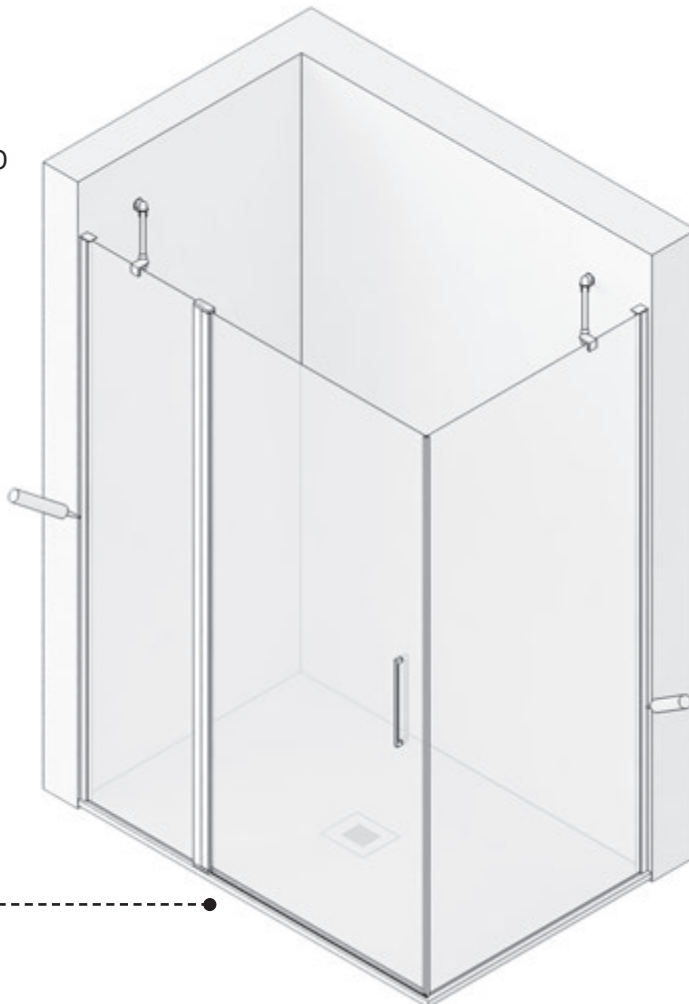
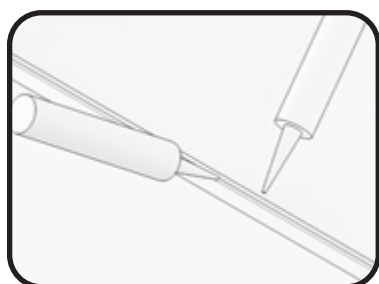



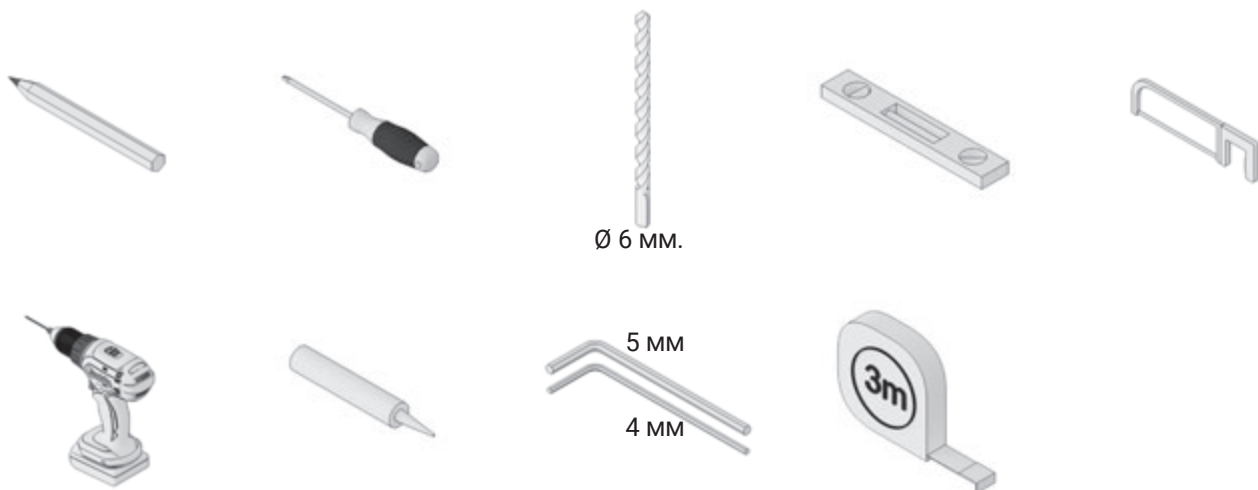





14

SELLAR CON SILICONA EL CONTORNO
EXTERIOR DE LA MAMPARA.



AFPF3



- | | | | | |
|--|---|---|---|---|
| <p>2X</p>  <p>HOJA FIJA PRE-MONTADA.</p> | <p>2X</p>  <p>PERFIL EXPANSOR HOJA FIJA.</p> | <p>2X</p>  <p>TAPA PERFIL EXPANSOR HOJA FIJA.</p> | <p>1X</p>  <p>HOJA ABATIBLE PRE-MONTADA.</p> | <p>2X</p>  <p>BARRA DE SUJECCIÓN FIJO.</p> |
| <p>1X</p>  <p>PERFIL DE ESTANQUEIDAD.</p> | <p>1X</p>  <p>ASA TIRADOR.</p> | <p>2X</p>  <p>GOMA IMÁN ANGULAR</p> | <p>1X</p>  <p>GOMA INFERIOR BARREDERA.</p> | <p>1X</p>  <p>GOMA ESTANQUEIDAD FIJO.</p> |
| <p>6X</p>  <p>TORNILLOS AUTORROSCANTES</p> | <p>6X</p>  <p>TAPONES CON BASES.</p> | <p>6X</p>  <p>TORNILLOS 4.2 X 32.</p> | <p>6X</p>  <p>TACOS N°6</p> | |