

# MANUAL DE MONTAJE

## AFPP3



### MAMPARA ANGULAR DE DUCHA

2 HOJAS ABATIBLES + 1 FIJA

## AFPP3

# 1

PRESENTAR LOS PERFILES EXPANSORES DE LA HOJA FIJA SOPORTE PUERTA Y 2ª HOJA ABATIBLE, EN PAREDES, SEGÚN CORESPONDA SU POSICIÓN, NIVELANDOLO, A 1 CM. DEL BORDE DEL PLATO DE DUCHA Y MARCAMOS TALADROS.

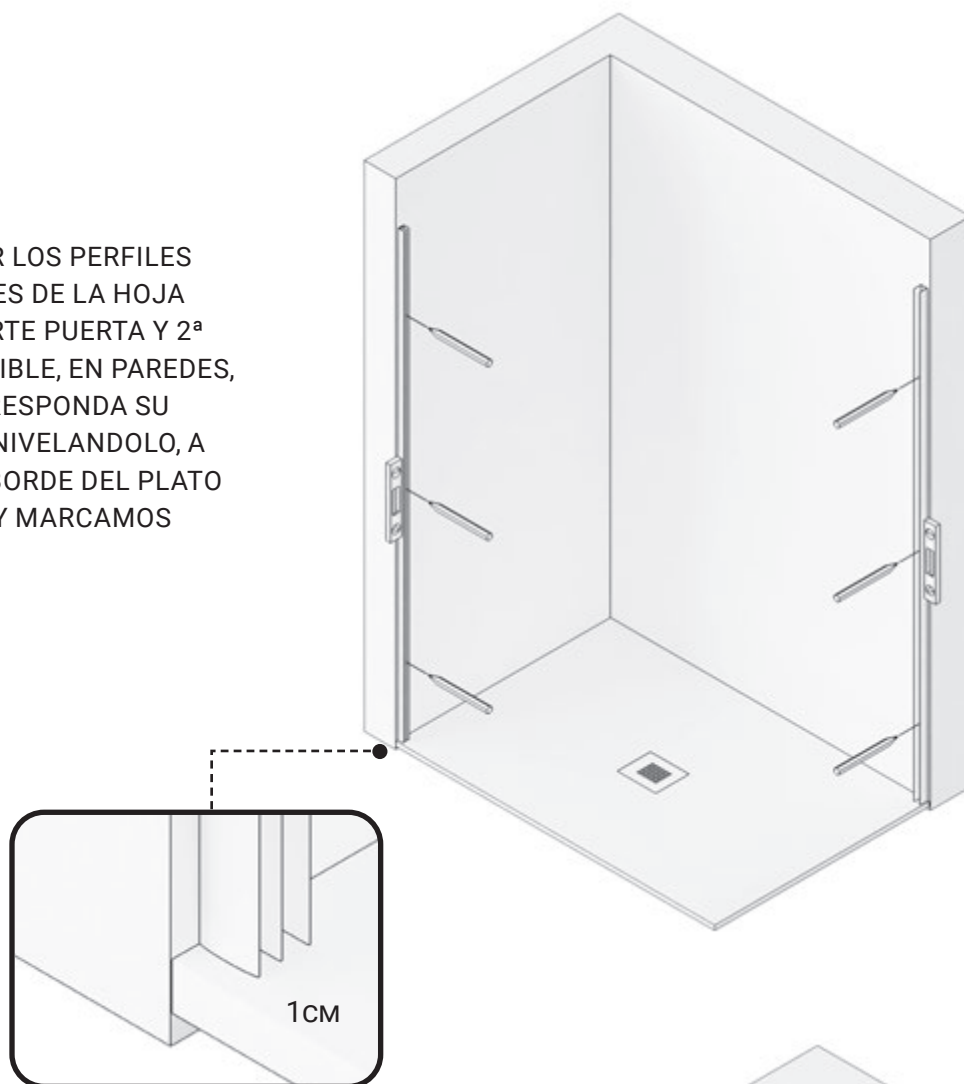

# 2

TALADRAR LA PARED CON BROCA Ø 6 MM.

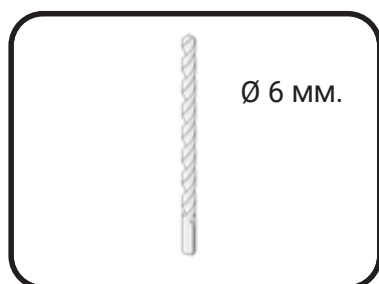

# 3

ATORNILLAR LOS PERFILES EXPANSORES DE HOJA FIJA Y HOJA ABATIBLE, FIJÁNDOLO CON TACOS DEL N° 6 Y LOS 6 TORNILLOS 4.2X32.



# 4

COLOCAMOS GOMA DE ESTANQUEIDAD INFERIOR EN LA HOJA FIJA SOPORTE PUERTA.



# 5

INTRODUCIMOS LA HOJA FIJA PRE-MONTADA EN SU MARCO EXPANSOR.



AFPP3

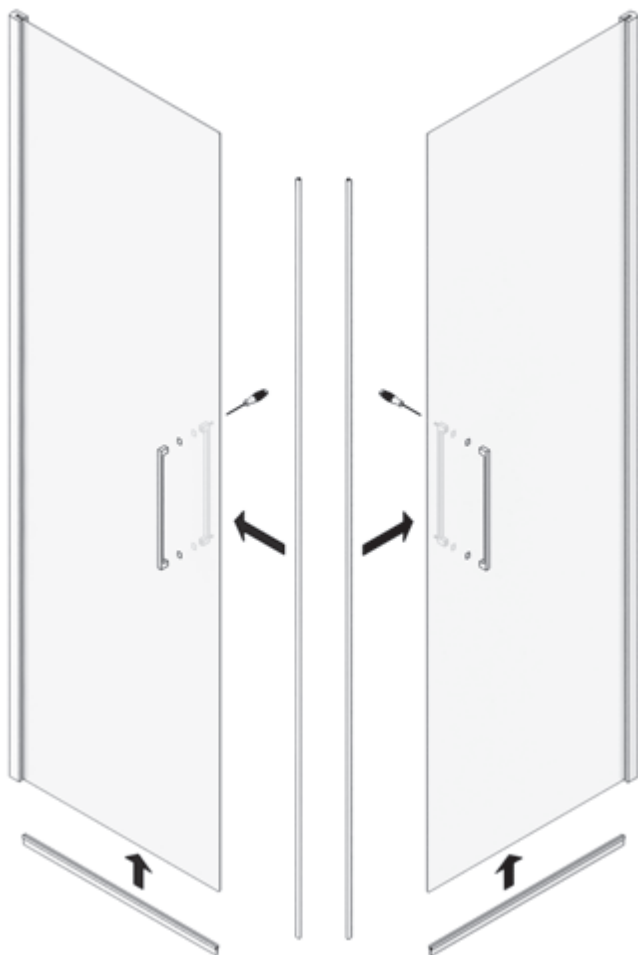

**6**

MONTAMOS ASAS TIRADOR, GOMAS INFERIORES BARREDERA Y GOMAS CIERRE IMÁN ANGULAR, EN LAS HOJAS ABATIBLES.

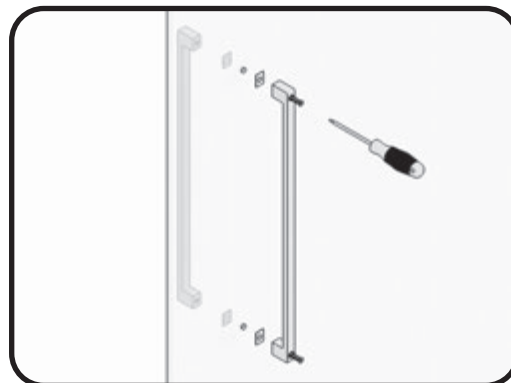

**7**

UNIMOS LA HOJA ABATIBLE A LA HOJA FIJA PRE-MONTADA, DESMONTANDO LA BISAGRA SUPERIOR PARA SU ANCLAJE, FIJANDOLA DESPUES.

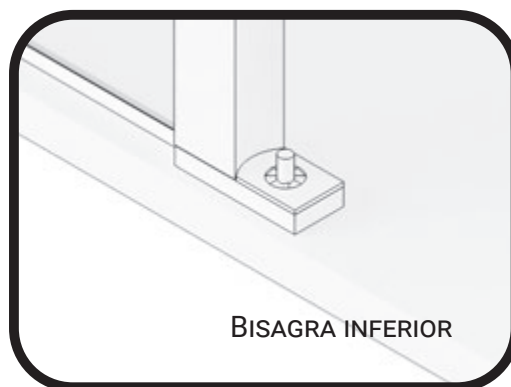

# 8

INTRODUCIMOS LA 2ª HOJA ABATIBLE EN SU PERFIL EXPANSOR.



# 9

APROXIMAMOS Y NIVELAMOS LAS HOJAS ABATIBLES JUNTO CON LA HOJA FIJA, RESPECTO AL CIERRE AL VÉRTICE, FIJAMOS LA HOJA FIJA Y LA 2ª HOJA ABATIBLE A SU CORRESPONDIENTES PERFILES EXPANSORES CON LOS 6 TORNILLOS AUTORROSCANTES Y SUS RESPECTIVOS TAPONES, POR EL INTERIOR DE LA DUCHA.

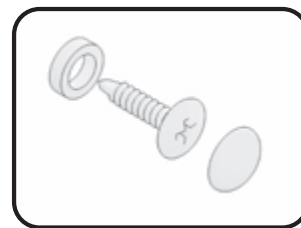

## AFPP3

# 10

PRESENTAMOS, NIVELAMOS Y MARCAMOS EL BRAZO DE SUJECCIÓN SUPERIOR DE LA HOJA FIJA, AJUSTANDO LA DISTANCIA AL CORTE DEL TUBO DEL MISMO Y FIJAMOS A PARED Y VIDRIO.

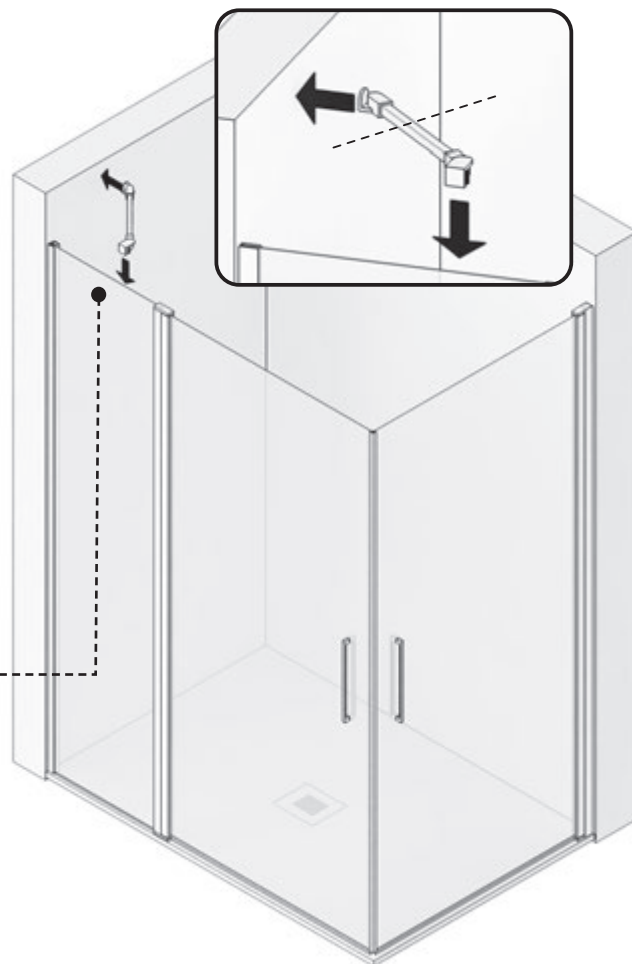
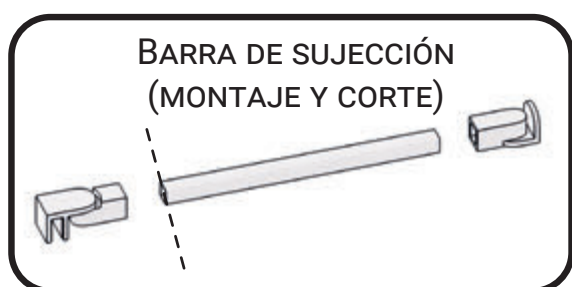

# 11

MEDIMOS, CORTAMOS EN ANGULO Y PEGAMOS EL PERFIL DE ESTANQUEIDAD POR DELANTE DE LAS HOJAS ABATIBLES.



# 12

COLOCAMOS LAS 2 TAPAS  
EMBELLECEDORAS SUPERIORES EN LOS  
PERFILES EXPANSORES.

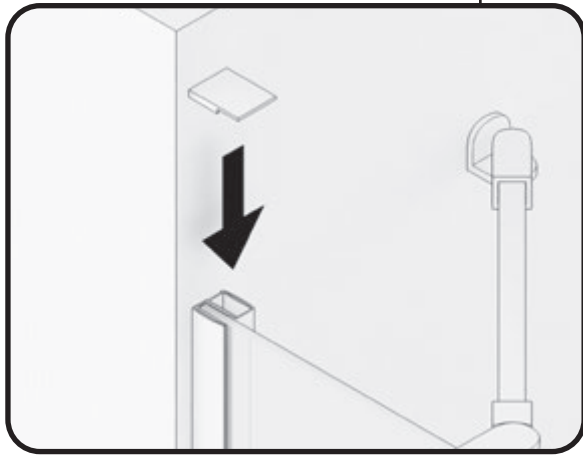





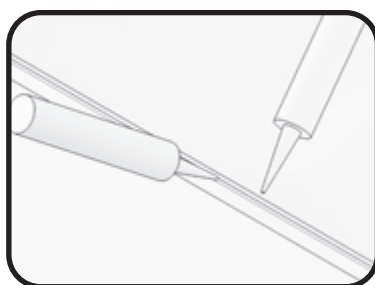



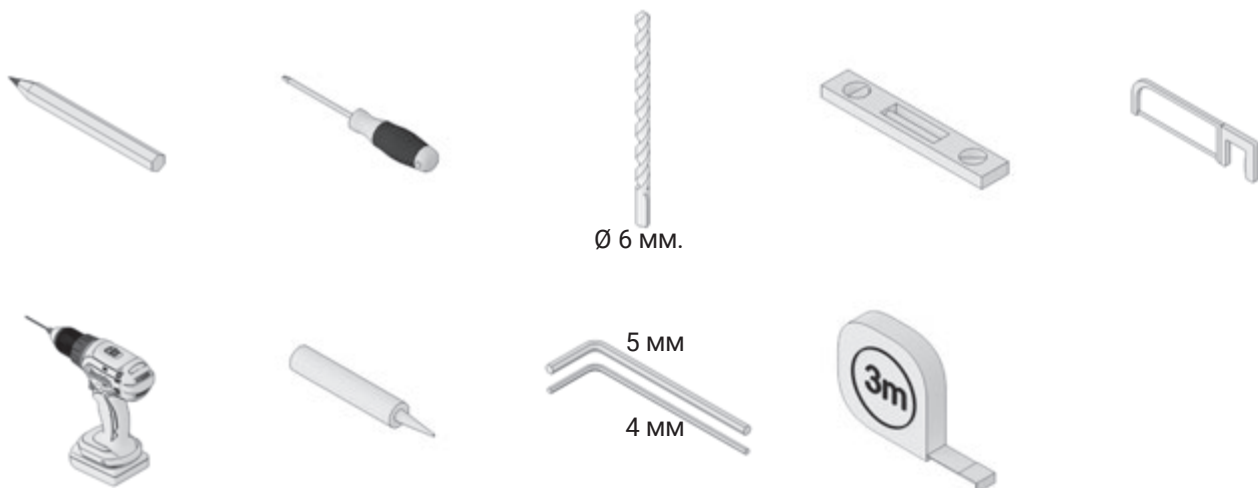







# 13

SELLAR CON SILICONA EL CONTORNO  
EXTERIOR DE LA MAMPARA.



# AFPP3



- 1X**  HOJA FIJA PRE-MONTADA.
- 1X**  PERFIL EXPANSOR HOJA FIJA.
- 1X**  TAPA PERFIL EXPANSOR HOJA FIJA.
- 2X**  HOJA ABATIBLE PRE-MONTADA.
- 1X**  PERFIL EXPANSOR HOJA ABATIBLE
- 1X**  TAPA PERFIL EXPANSOR HOJA ABATIBLE
- 1X**  BARRA DE SUJECCIÓN FIJO.
- 1X**  PERFIL DE ESTANQUEIDAD.
- 2X**  ASA TIRADOR.
- 2X**  GOMA IMÁN ANGULAR
- 1X**  GOMA INFERIOR BARREDERA.
- 1X**  GOMA ESTANQUEIDAD FIJO.
- 6X**  TORNILLOS AUTORROSCANTES
- 6X**  TAPONES CON BASES.
- 6X**  TORNILLOS 4.2 X 32.
- 6X**  TACOS N°6